



# MADE TO MEASURE CHROMATIC MAP REPORT

Customer:  
**Sample Report**

Part Number:  
**N/A**

Revision:

Part Name:  
**Black Sample Part**

Reference Model:  
**M2M\_sample.stp**

Units of measure:  
**inches**

Alignment Method:  
**Datum**

Sample Identification:  
**Black**

Equipment Used:

**Mitutoyo 710 w/Metris LC-65 Laser**

Inspector:  
**Erik Gustafson**

Date:  
**June 04, 2019**

### Deviation of Measured Data to CAD Model

CAD Model set as Reference  
Measured Data used as Test

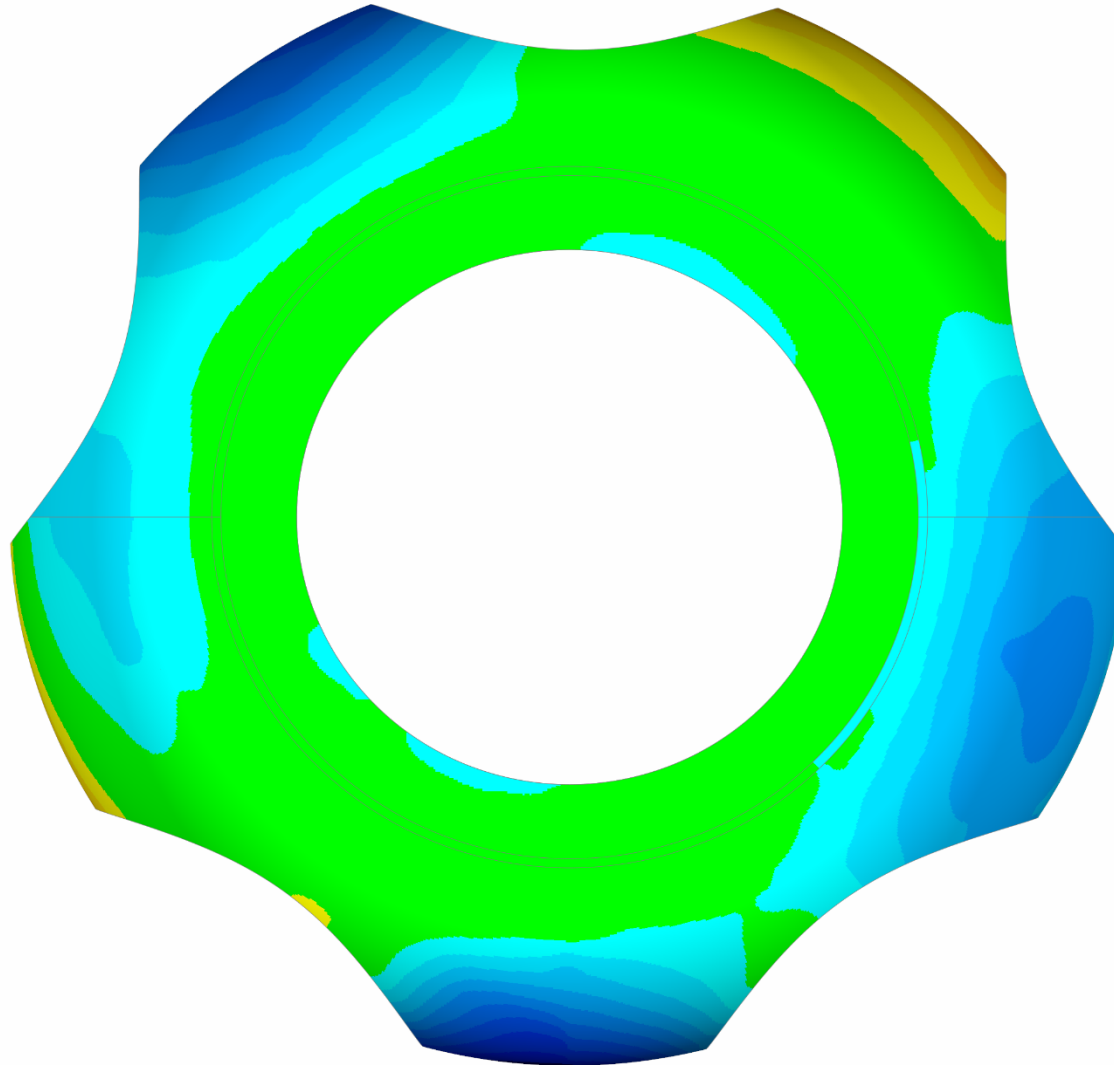

### Deviation of Measured Data to CAD Model

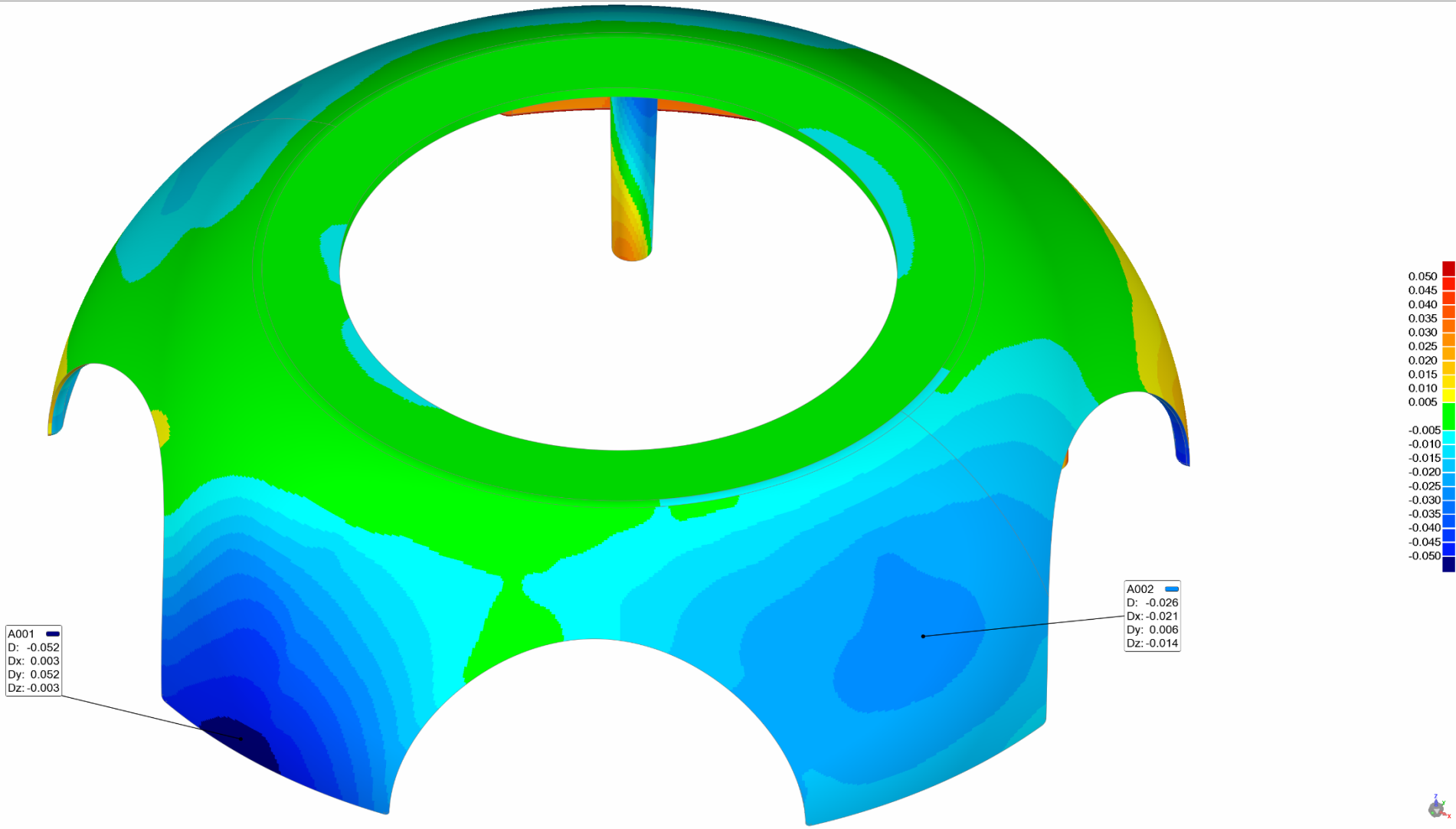

### Deviation of Measured Data to CAD Model

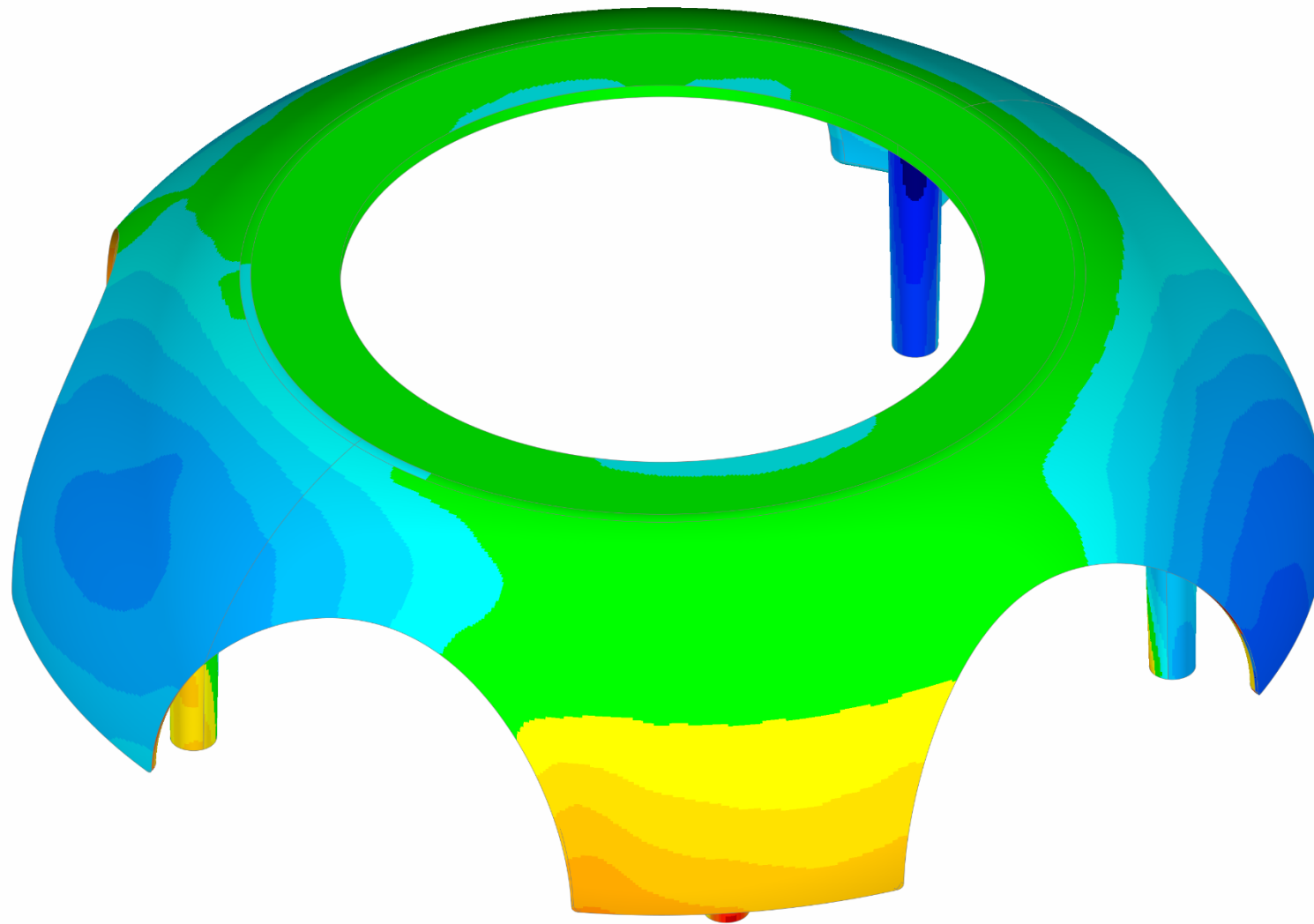

### Deviation of Measured Data to CAD Model

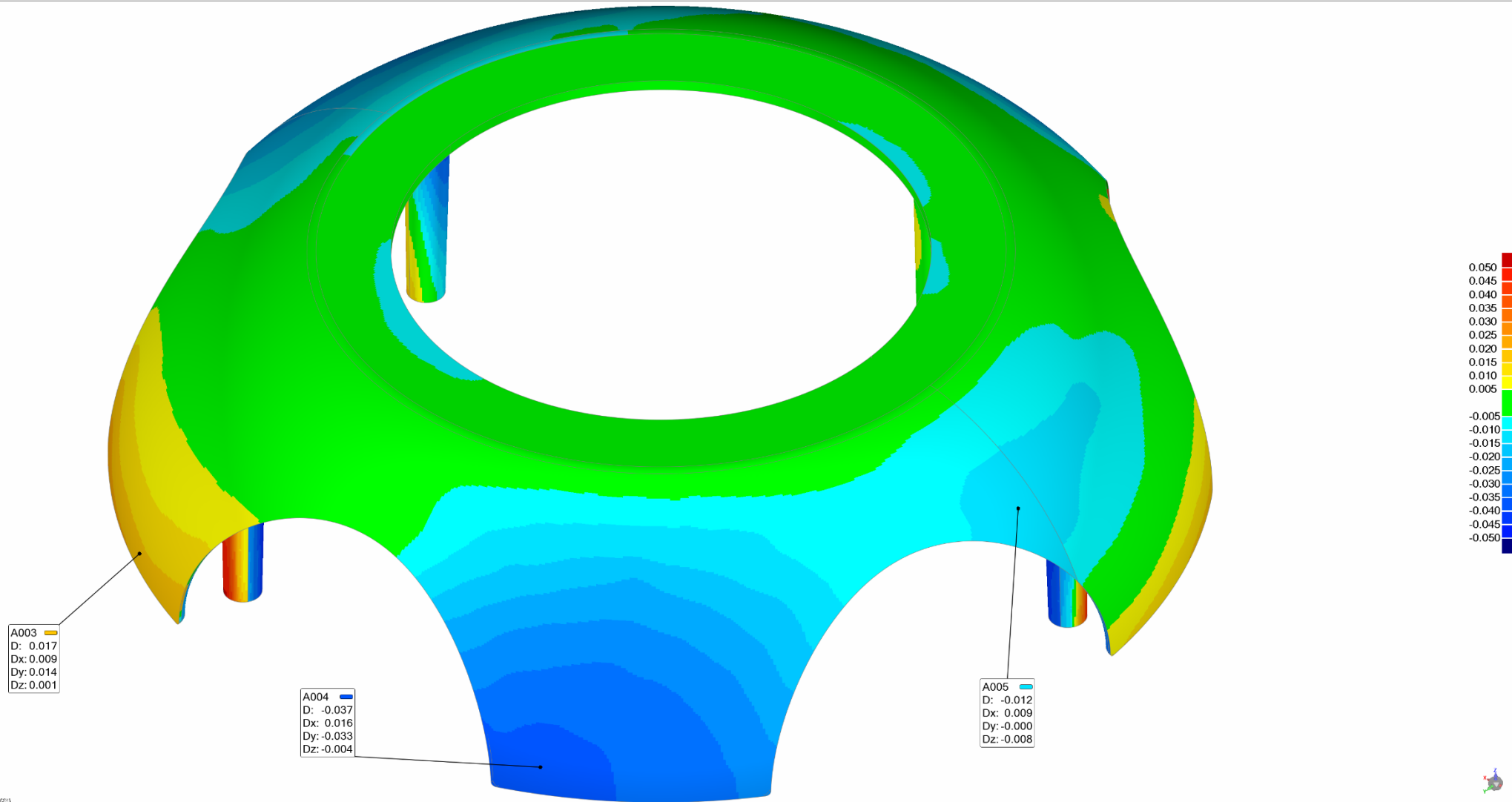

### Deviation of Measured Data to CAD Model

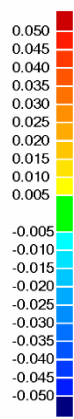
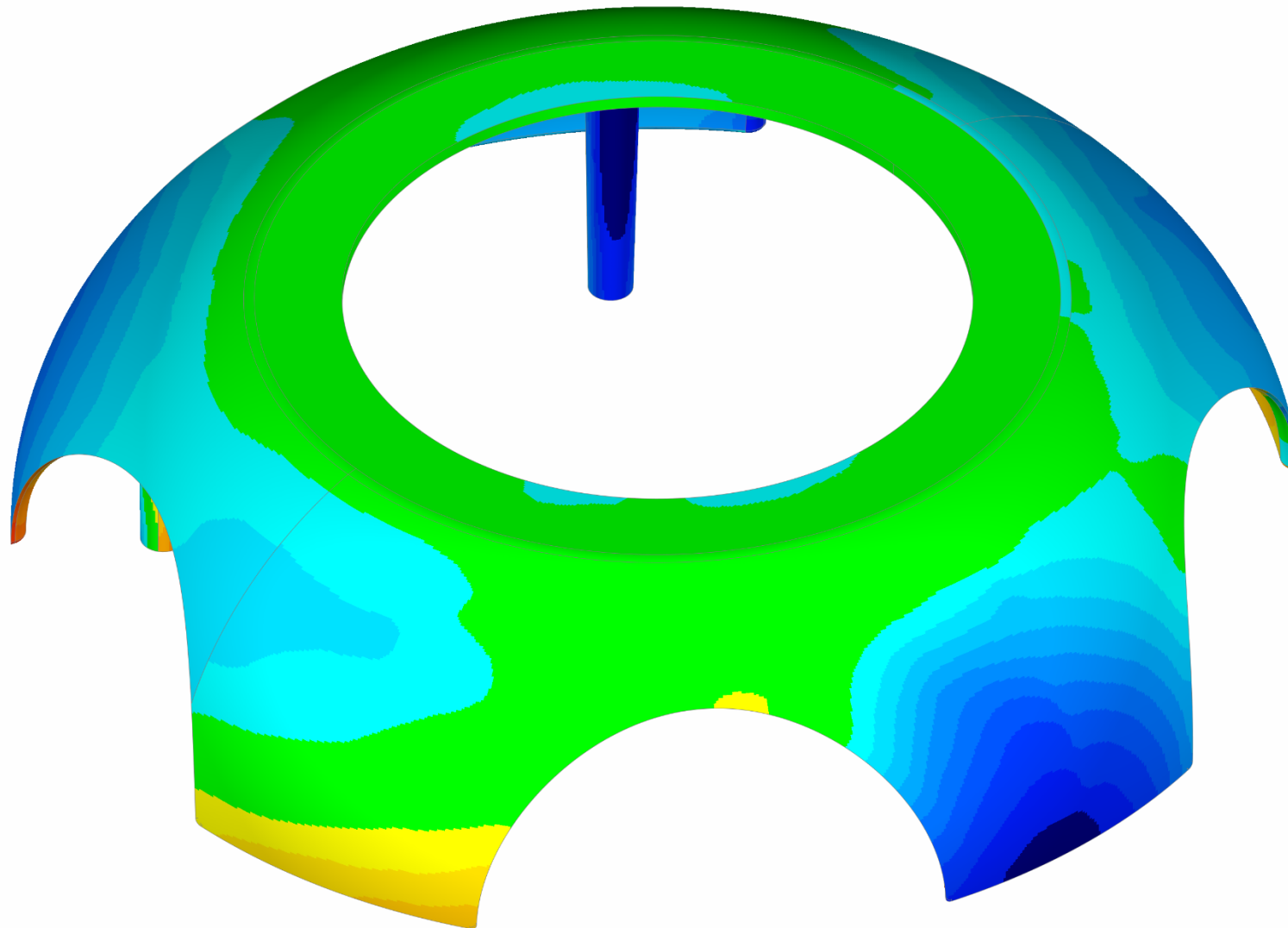

### Deviation of Measured Data to CAD Model

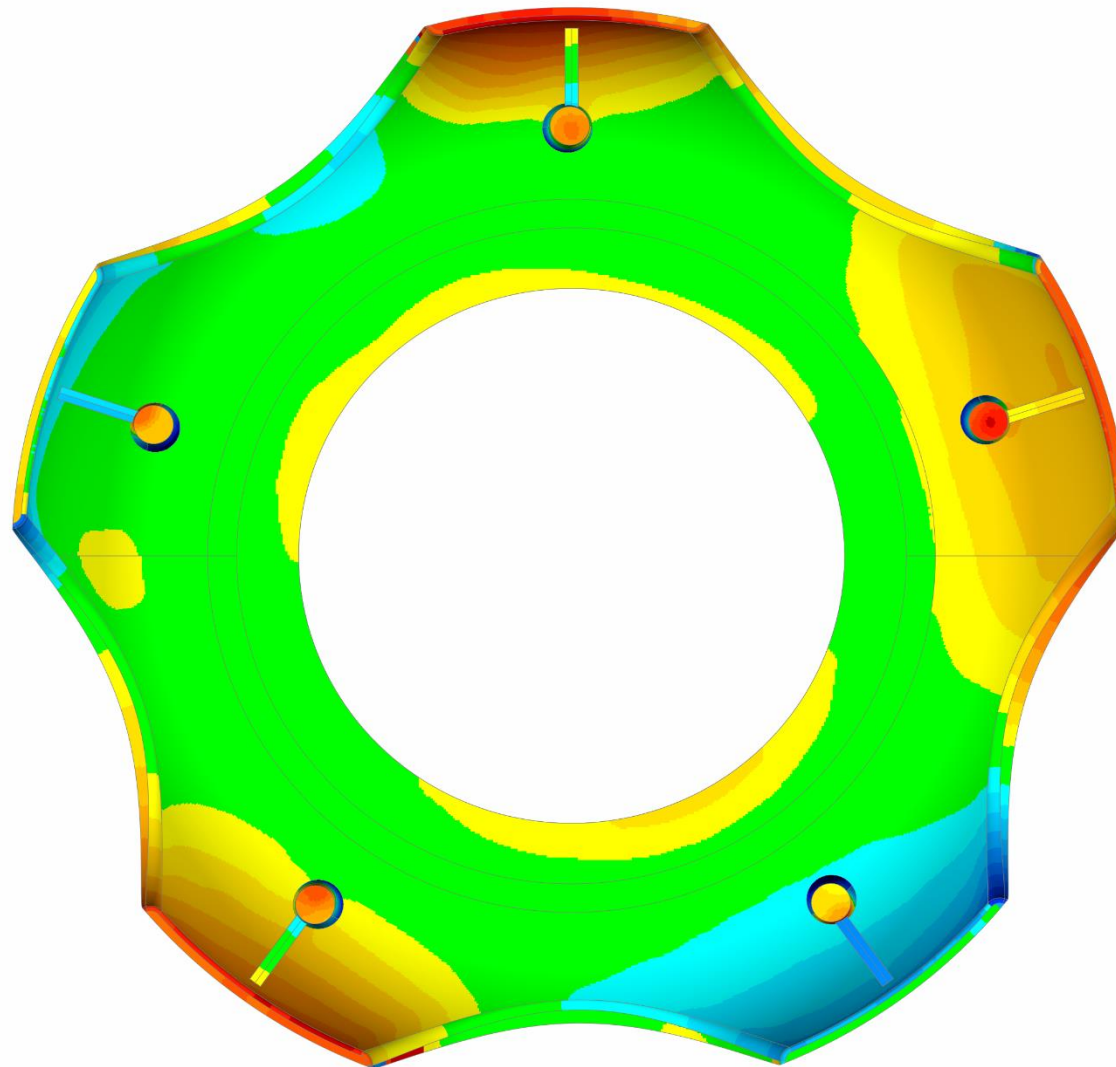

### Deviation of Measured Data to CAD Model

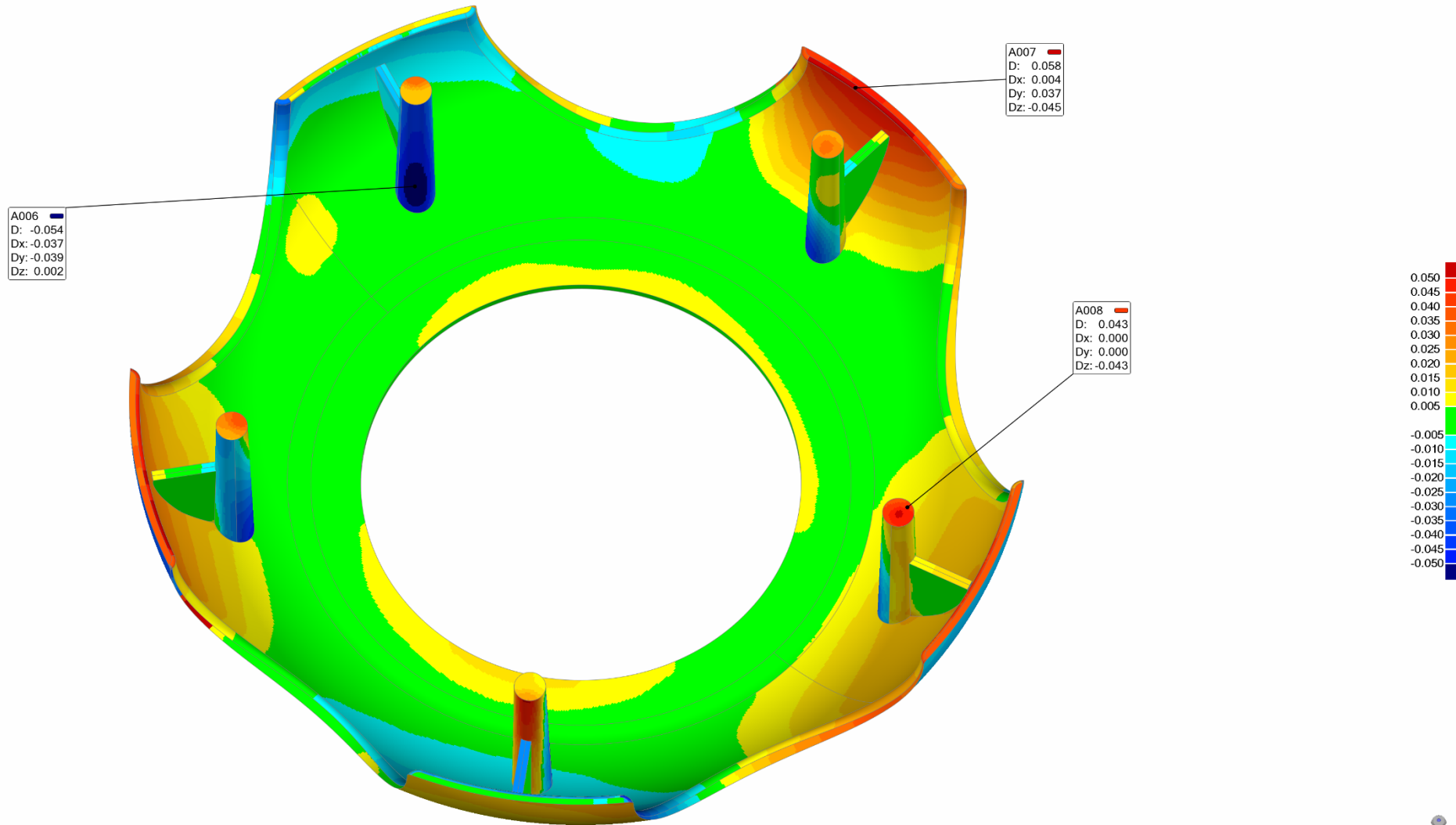



### Deviation of Measured Data to CAD Model

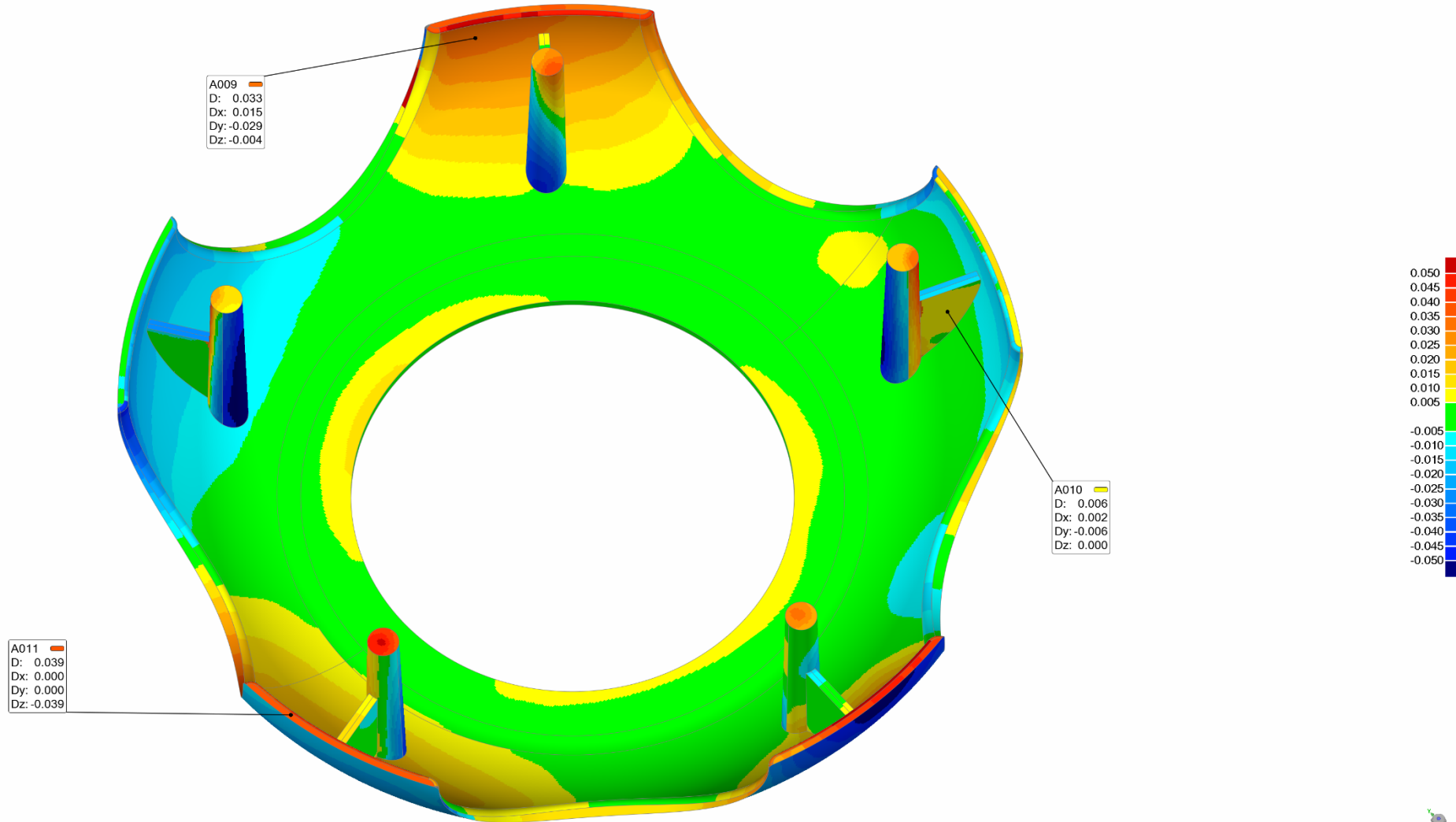

### Deviation of Measured Data to CAD Model

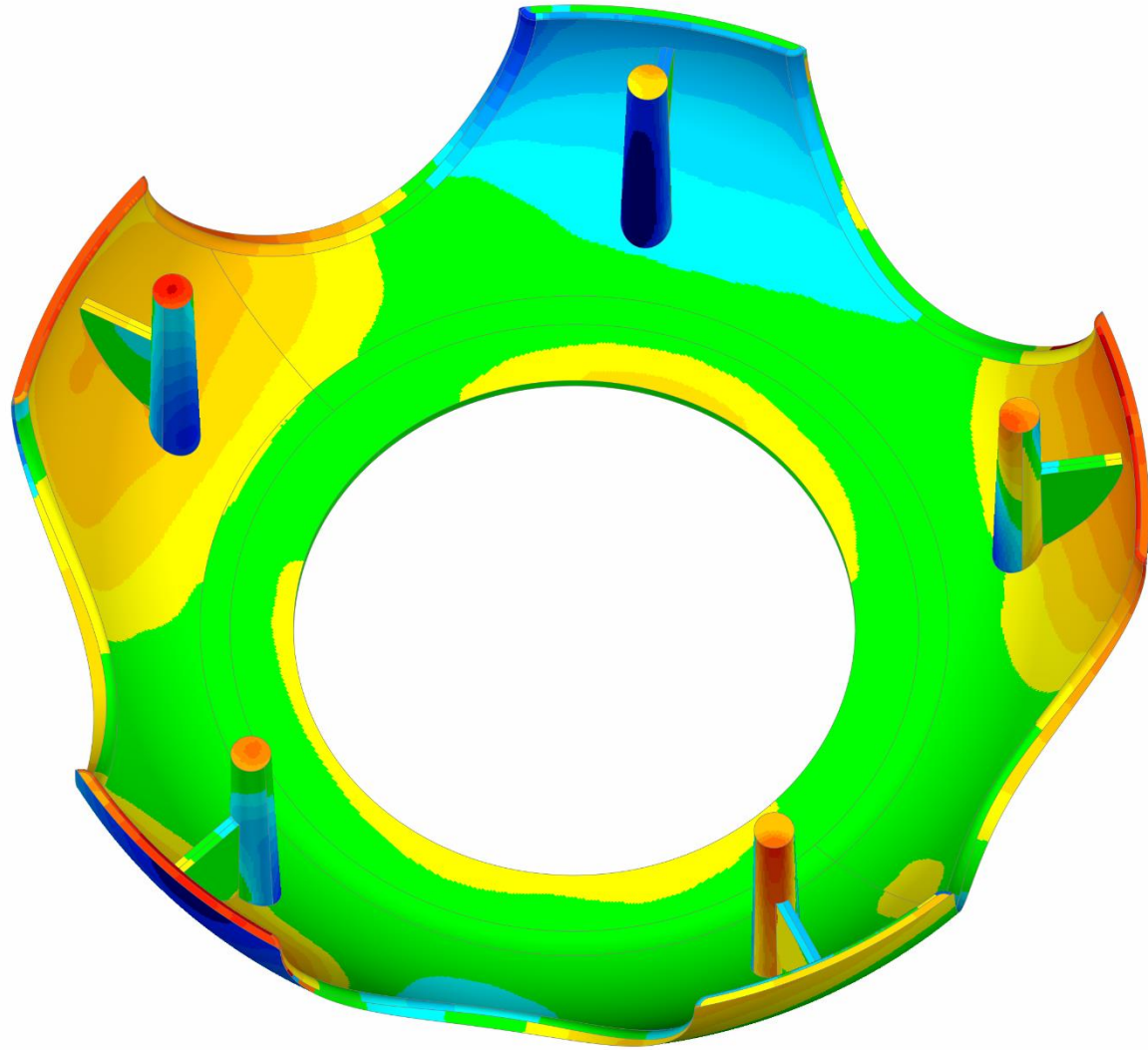

### Deviation of Measured Data to CAD Model

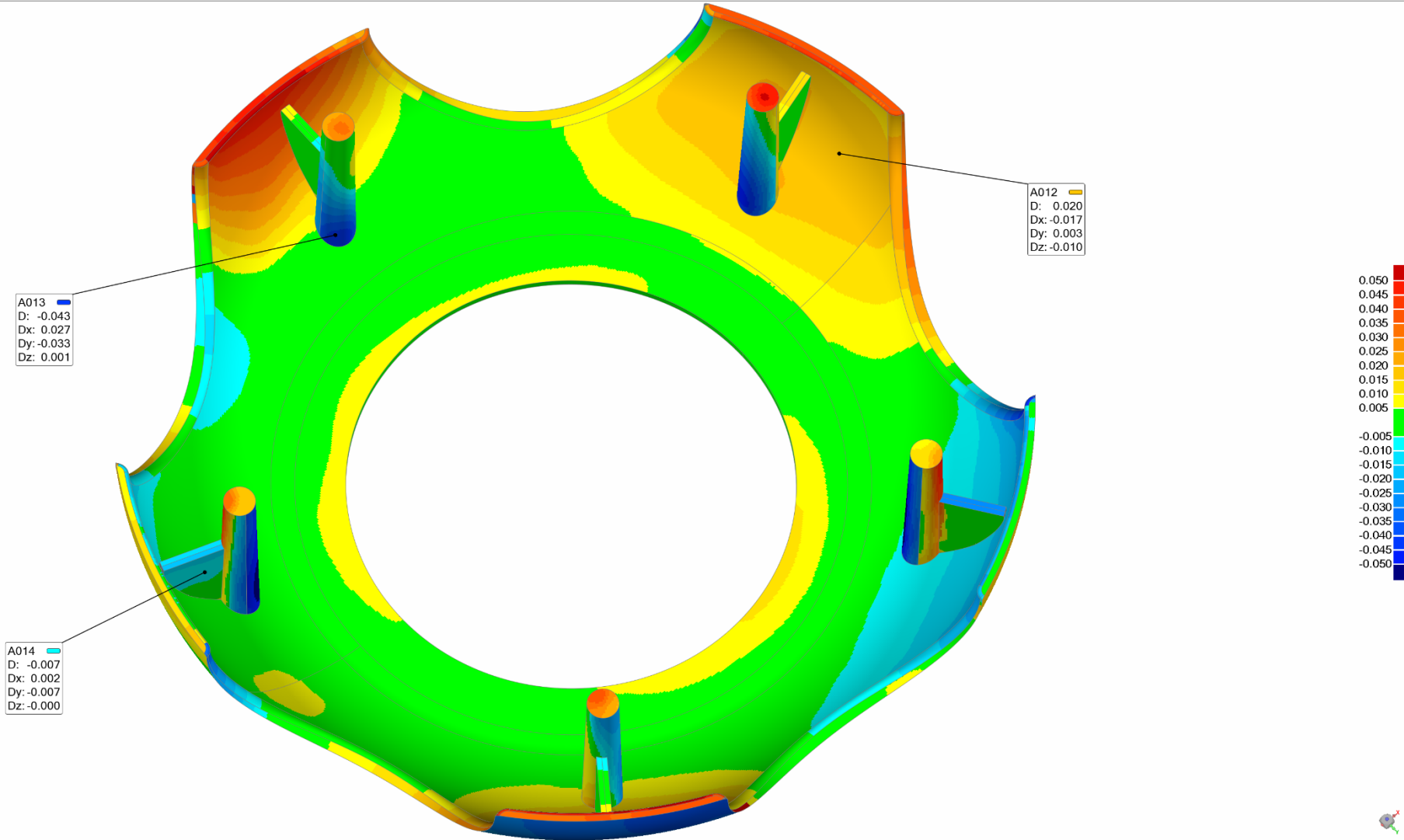

### Cross Section Locations

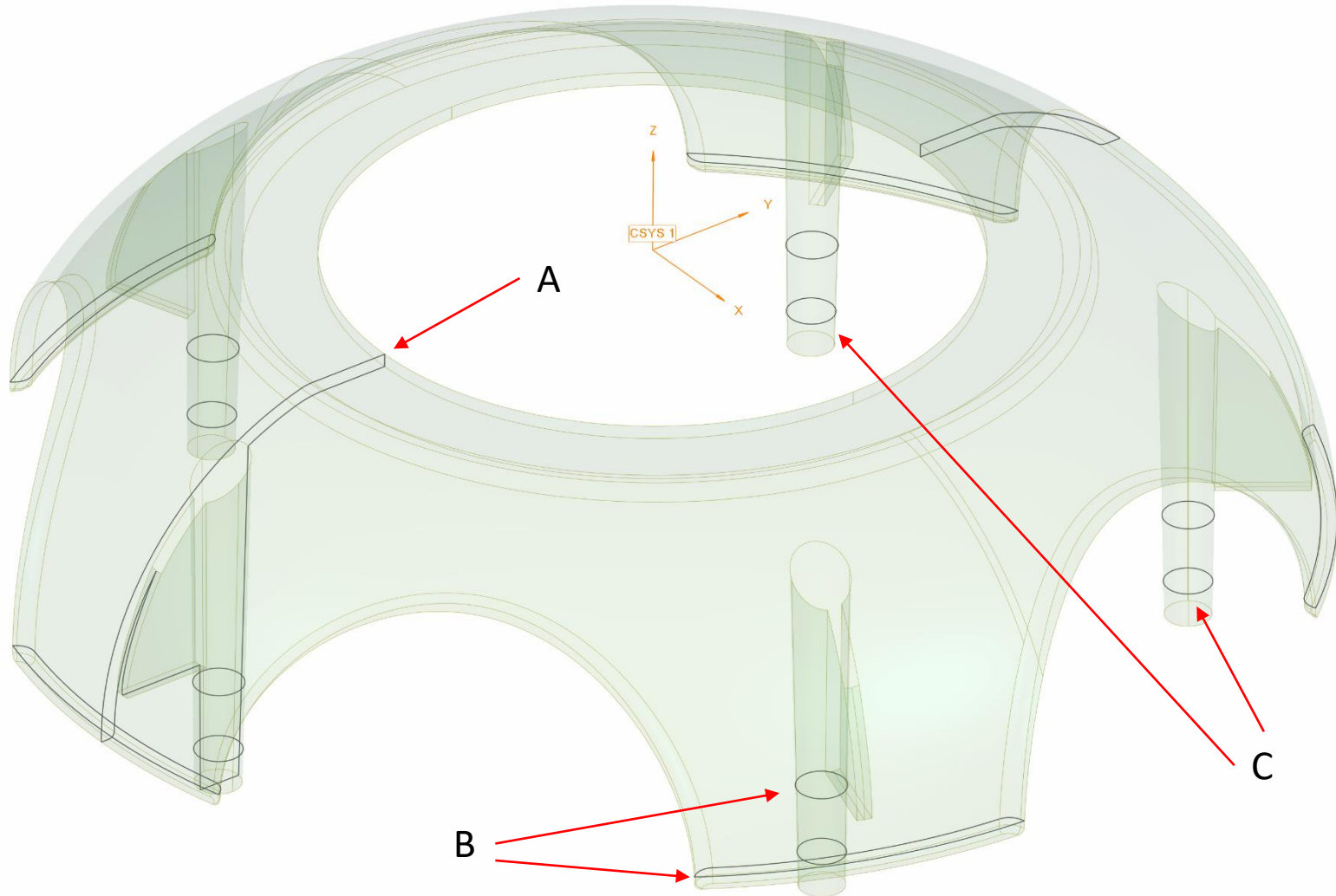

### Cross-Section A

CAD entities shown in burgundy  
Part geometry in black

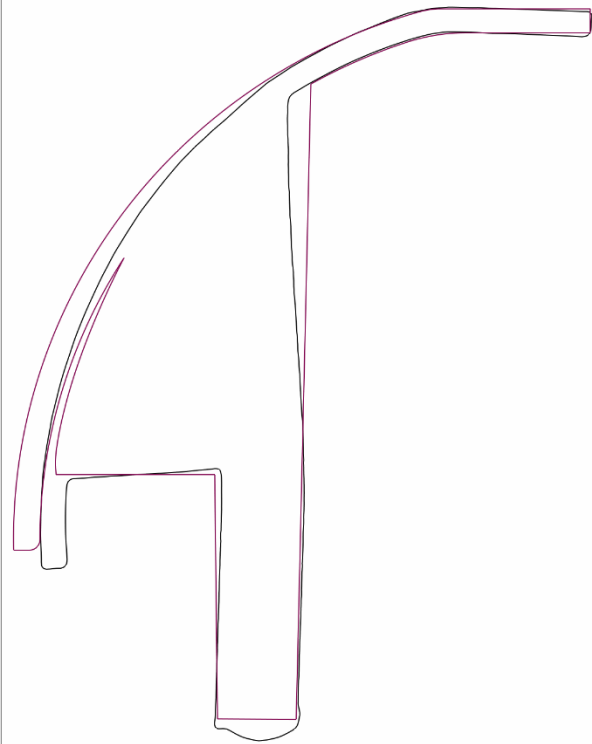

### Cross-Section A

CAD entities shown in burgundy  
Part geometry in black

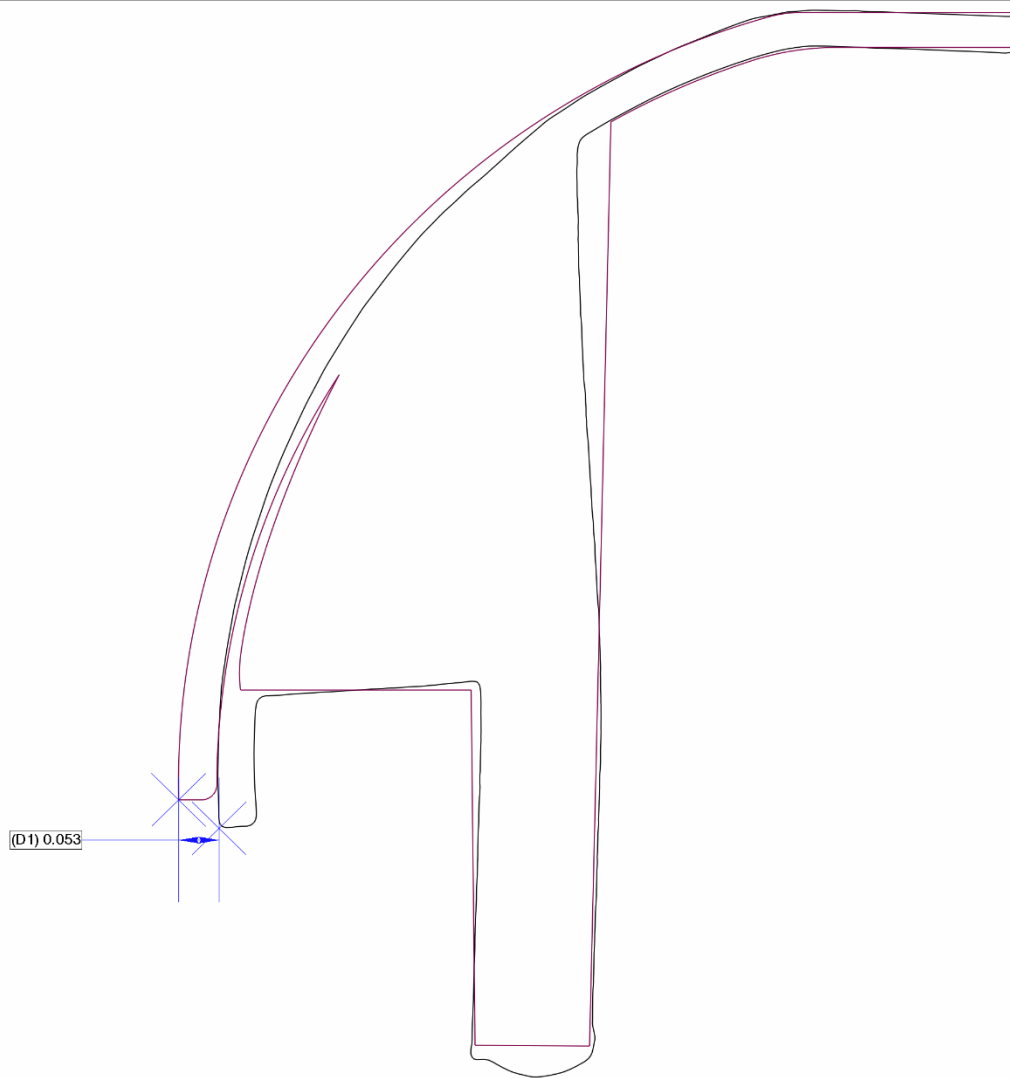

### Cross-Section B

CAD entities shown in burgundy  
Part geometry in black

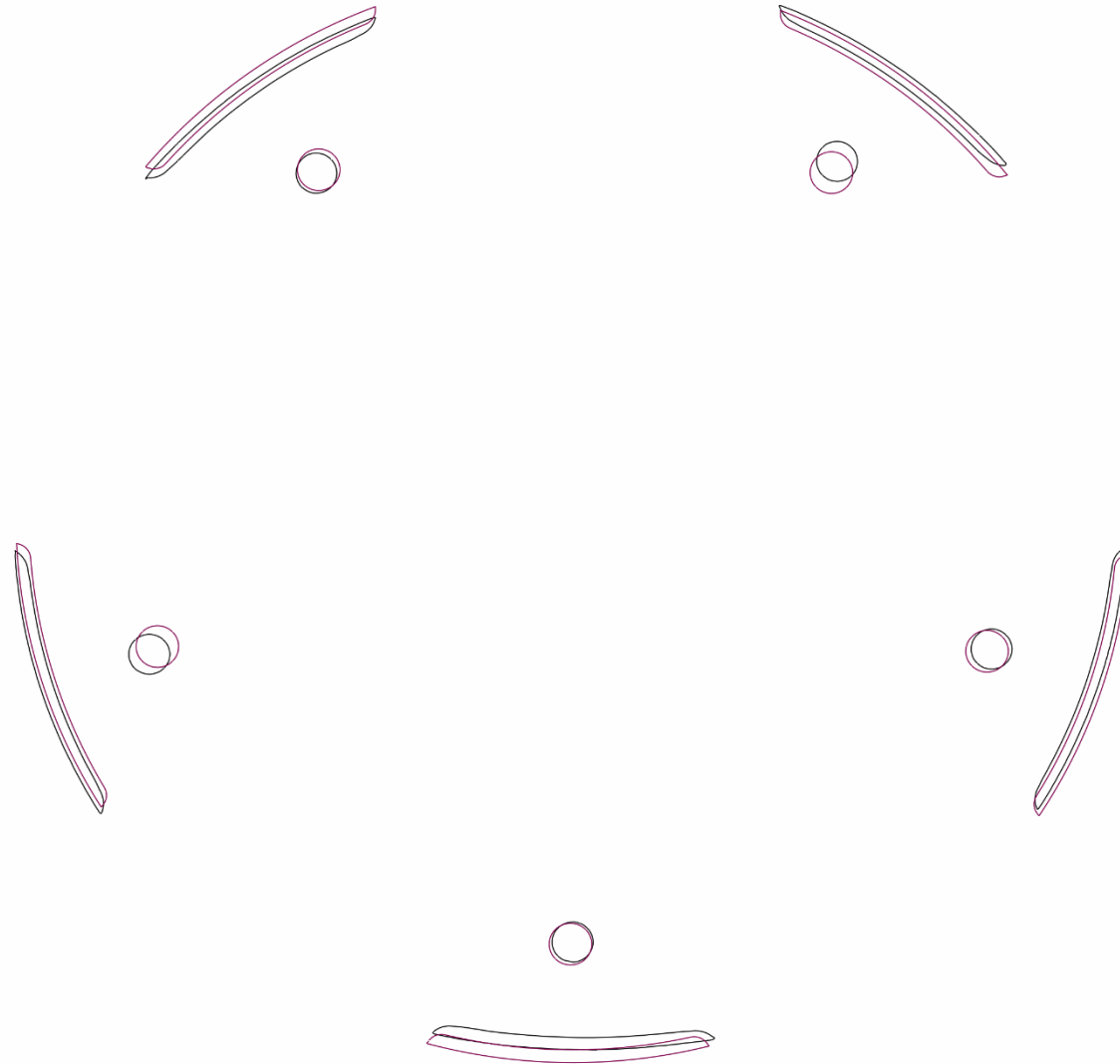

### Cross-Section B

CAD entities shown in burgundy  
Part geometry in black

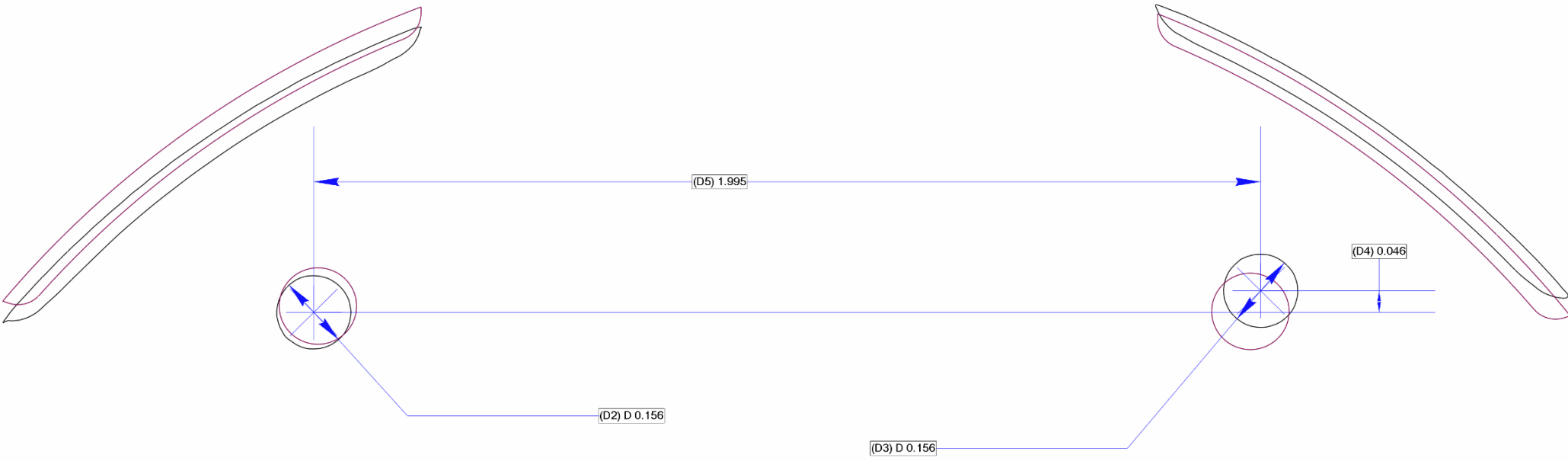



### Cross-Section C

CAD entities shown in burgundy  
Part geometry in black

